

# KRAISSL DUPLEX STRAINERS & FILTERS MODEL 72FS and 72FHS SERIES CAST STEEL or STAINLESS STEEL

Pressure Range - 200 to 1480 PSIG

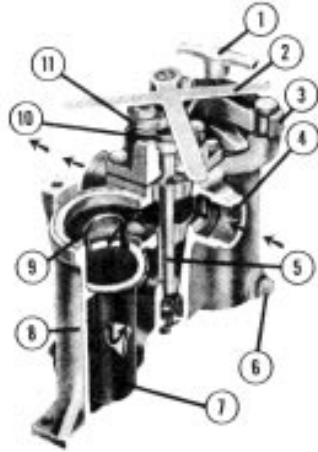

## FEATURES

- 1- Hand clamp requires no special tools.
- 2 - Valve handle shields side in use.
- 3 - Accessible swing yoke closure for easy basket cleaning.
- 4 - Continuous flow without interruption during changeover.
- 5 - Tapered valve plug for durability.
- 6 - Drain connections on each basket chamber.
- 7 - Interchangeable strainer, filter and double element baskets.
- 8 - Bodies individually pressure tested to U.L specifications.
- 9 - Spring handle holds basket on seat.
- 10 - Independent gland for external stem packing access.
- 11 - Adjustable locking flange establishes valve clearance.
- 12- Mounting feet provided.



A2211B (0302)



## PURPOSE

Kraissl pipeline strainers and filters protect pumps, engines, nozzles, valves, heat exchangers and other expensive pipeline equipment from harmful flow contamination by catching dirt and debris.

## APPLICATION

Kraissl duplex strainers and filters provide a simple, cost effective way to separate particle impurities from fluid systems. Duplex strainers are ideal for applications where continuous flow must be maintained with no flow interruption for basket cleaning.

Kraissl strainers are listed by Underwriters Laboratories, Inc. (U.L.) and are individually tested to U.L. quality control specifications. These cast pipeline strainers are manufactured according to international standard A.S.T.M. F1199 for use in industrial and marine applications.

## DESIGN SPECIFICATIONS

Model 72FS and 72FHS series duplex strainers are furnished in both standard or high pressure models with flanged port connections. Threaded NPT, socket weld or butt weld end models are also available, described in other bulletins. Internal channels are 100% full-flow, having the same cross-sectional area as the equivalent pipe size. Standard pressure models are furnished with our quick-opening, hand-clamp closure for easy access. High pressure models have stud-and-nut / bolted body cover closures.

Materials of construction include rugged cast carbon steel bodies, covers, and iron valve plugs, and brass, carbon steel, stainless steel or monel baskets. Special valve plugs can also be furnished in bronze, stainless steel or other materials. All stainless steel models are also available in cast 316 stainless steel, 304 stainless steel or other special stainless alloys.

These duplex strainers have a built-in, tapered plug valve that directs flow through either side without shutting off the flow. A valve handle guard shields the side in use. The standard valve handle swings over the inlet port. Special reverse valve handles that swing over the outlet port can also be furnished. Drain plugs are provided in each of the valve and basket chambers. An adjustable locking flange holds the valve plug on its seat. A separate external gland is provided to allow easy access to valve stem packing without complete disassembly, even while in service.

Strainer baskets are fabricated from perforated metal. The smallest common perforation size is 1/64 inch in brass and 1/32 inch in stainless steel. Filter baskets are manufactured by using fine mesh wire cloth over supporting perforated metal. Interchangeable strainer, filter and double element baskets provide a flexible range of operating choices. The basket is held on its seat by a spring basket handle. Normal flow is through the interior of the basket which then contains the collected debris when the basket is lifted out for cleaning. Reverse flow is also possible if desired. Magnet inserts are available to help eliminate fine metallic ferrous particles.

All high pressure ("H") models with stud and nut closure are supplied with balancing valve assemblies to equalize pressure and ease valve turning. These should be specified on standard pressure models when used above the following pressures: **3/4 inch through 1 1/2 inch inclusive-100 psig; 2 inch through 3 inch-80 psig; 4 inch through 8 inch-15 psig.**

An optional lifting jack can be provided to lift the valve plug off its seat for ease in valve turning in rough service on sizes 1 through 4 inch. A lifting jack is standard on 5, 6 and 8 inch sizes and all "H" High Pressure models except size one inch.

# KRAISSL CAST STEEL\* DUPLEX STRAINERS - FLANGED PORTS

**MODEL 72FS SERIES - CLASS 150**  
**HAND CLAMP (YOKE) CLOSURE**  
 For Standard Pressure to 200 psig

**MODEL 72FHS SERIES - CLASS 300\*\* & 600\*\***  
**STUD AND NUT COVER CLOSURE**  
 For High Pressure  
 Class 300 to 720 psig      Class 600 to 1480 psig

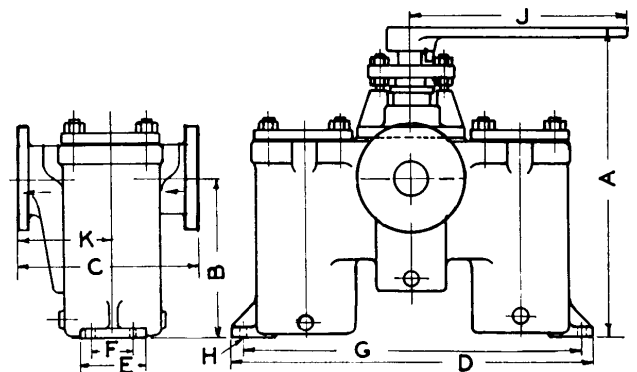
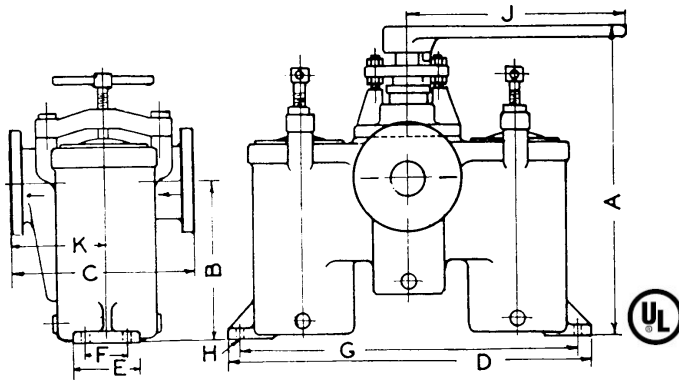

## OUTLINE DIMENSIONS in inches, subject to casting & assembly variations.

MODEL NO	PIPE SIZE NPT	APPROX NET WGT, LBS			A***	B	C			D	E	F	G	H	J	K		
		CL150	CL300	CL600			CL150	CL300	CL600							CL150	CL300	CL600
		72-33F(H)S	1"	32			35	41	10 1/8							5 1/8	6 3/4	7 1/4
72-35F(H)S	1 1/4"	60	66	72	15 5/8	7 15/16	8 1/4	8 5/8	9 3/8	14	2 3/4	1 1/2	12 3/4	7/16	12 1/8	4 1/2	4 3/4	5 1/16
72-37F(H)S	1 1/2"	61	67	74	15 5/8	7 15/16	8 1/4	8 3/4	9 3/8	14	2 3/4	1 1/2	12 3/4	7/16	12 1/8	4 1/2	4 3/4	5 1/16
72-39F(H)S	2"	115	127	139	16	7 1/2	10 3/8	10 1/2	11 5/8	20 1/2	3	1 7/8	19 1/2	9/16	12 1/8	5 3/4	6	6 1/4
72-41F(H)S	2 1/2"	120	132	145	16	7 1/2	10 3/8	11 1/4	12	20 1/2	3	1 7/8	19 1/2	9/16	12 1/8	5 3/4	6 1/16	6 3/4
72-43F(H)S	3"	159	175	193	19 1/4	10 3/4	10 7/8	11 1/2	12 1/4	20 1/2	3	1 7/8	19 1/2	9/16	12 1/8	6 1/4	6 5/8	7
72-47F(H)S	4"	285	314	345	22 1/8	12 3/4	14 3/4	15 3/8	16 3/8	25 1/4	3 1/4	2	24	5/8	12 1/8	6 1/4	8 9/16	9 1/8
72-49F(H)S**	5"	390	429	471	26 1/8	15 3/8	17 3/4	18 3/4	19 1/4	27 3/4	3 1/4	2	27	5/8	14	9 7/8	10 1/4	10 3/4
72-51F(H)S**	6"	655	721	793	26 7/8	15 3/16	20 5/8	21 1/2	22 3/8	34 1/2	3 1/4	2	33	5/8	14	11 5/8	12 3/16	12 5/8
72-53F(H)S**	8"	1675	1865	-	37 5/16	15 9/16	32 1/2	33 3/8	-	47 3/8	10 3/4	9	46	5/8	14	15 1/2	16 1/4	-

\*ASTM A216 WCB - Cast Carbon Steel. Cast 304 SS - ASTM A351-CF8. Cast 316 SS - ASTM 351-CF8M.

\*\* Special Model 72FHS-150 series with Class 150 Flanges for 230 psig Max. W.P. also available. Please contact factory.

\*\*\* Dimension includes lifting jack on all except 72-33F(H)S where L.J. is not available. L.J. is standard only on 5", 6" and 8" and all Cl. 300 & 600 models.

## DOUBLE ELEMENT BASKETS

These units can be supplied with our patented double-element baskets which are easily disassembled for cleaning and provide greater straining areas in the same housing.

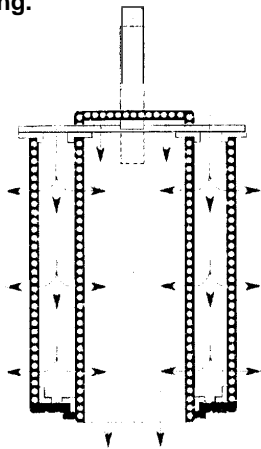

A2211B (0302)

## SINGLE ELEMENT BASKET DATA

Use Double Element Baskets for greater straining area.

MODEL NUMBER	INCH PIPE SIZE	INTERNAL PIPE AREA SQ. IN.	BASKET DIMENSIONS		TOTAL SCREEN AREA SQ. IN.	APPROX. OPEN SCREEN AREA SQ. IN.		RATIO OF OPEN AREA TO PIPE AREA	
			O. D.	LENGTH		1/16" HOLE	1/32" HOLE	1/16" HOLE	1/32" HOLE
						DIA.*	DIA.**	DIA.*	DIA.**
72-31(D)F(H)S	3/4	0.533	1 15/16	3 15/16	26.9	10.8	7.5	20.3:1	14.1:1
72-33(D)F(H)S	1	0.864	1 15/16	3 15/16	26.9	10.8	7.5	12.5:1	8.7:1
72-35F(H)S	1 1/4	1.495	1 15/16	6 3/8	41.8	16.7	11.7	11.2:1	7.8:1
72-37F(H)S	1 1/2	2.036	1 15/16	6 3/8	41.8	16.7	11.7	8.2:1	5.7:1
72-39F(H)S	2	3.355	3 1/2	5 1/8	66.0	26.4	18.5	7.4:1	5.5:1
72-41F(H)S	2 1/2	4.788	3 1/2	5 1/8	66.0	26.4	18.5	5.5:1	3.9:1
72-43F(H)S	3	7.393	3 1/2	8 3/8	102	40.8	28.6	5.5:1	3.9:1
72-47F(H)S	4	12.73	4 1/8	10 1/2	149	59.6	41.7	4.7:1	3.3:1
72-49F(H)S	5	20.006	5	13	224	89.6	62.7	4.5:1	3.1:1
72-51F(H)S	6	28.891	7	11 1/2	291	116	81.5	4.0:1	2.8:1
72-53F(H)S	8	50.03	9	16	516	206	144	4.1:1	2.9:1

\* Based on 40% open area.

\*\* Based on 28% open area.

## OTHER PRODUCTS

Our product lines of cast iron, bronze, aluminum, steel and stainless steel simplex and duplex strainers including threaded port cast iron models are covered in separate bulletins. Units can also be furnished in special metals and higher pressure / temperature ratings.

**KRAISSL COMPANY, INC.**  
 299 WILLIAMS AVENUE  
 HACKENSACK, NJ 07601-5225  
 Phone: (201)342-0008, Fax: (201)342-0025  
 E-mail: Kraissl@aol.com